

XILIA

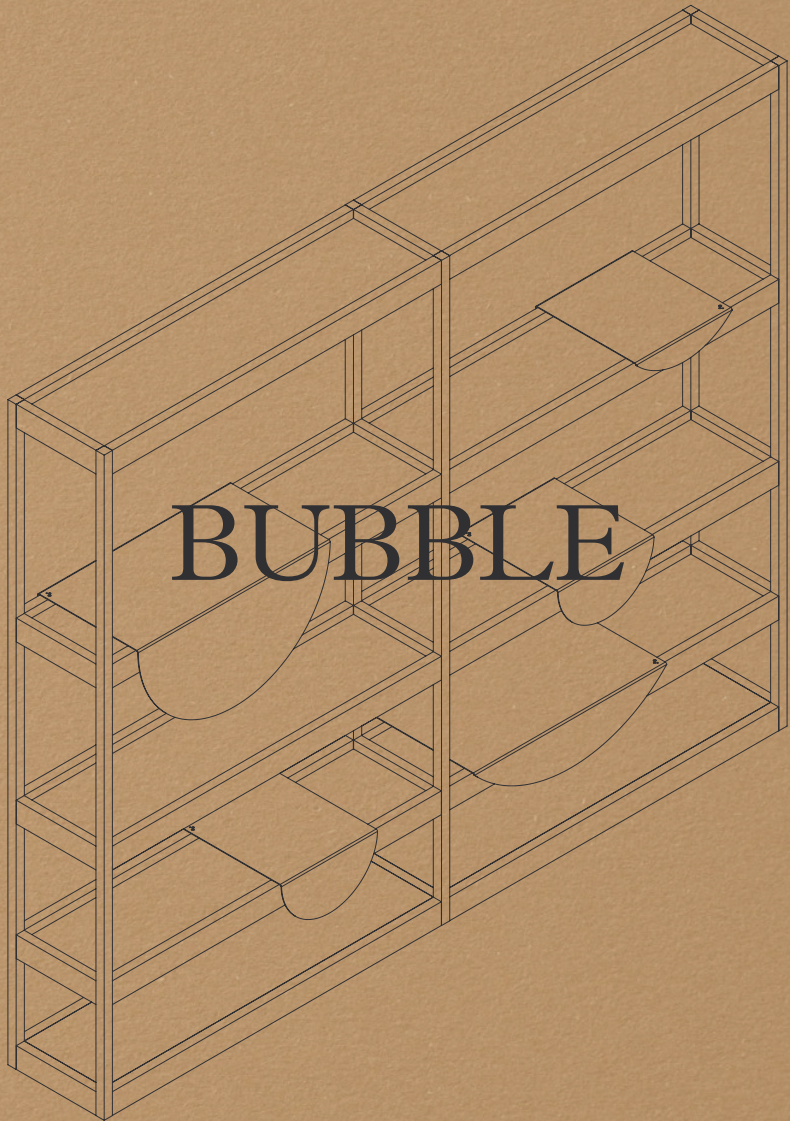

DYNAMIC MODULAR BOOKCASE



X I L I A

BUBBLE DYNAMIC MODULAR BOOKCASE  
DESIGN: GIANMARCO MIOLO

## Dinamica, flessibile e vivace Dynamic, flexible and playful

IT Bubble è una libreria modulare disegnata da Gianmarco Miolo, che unisce il rigore formale e la dinamicità delle forme. Ispirata all'architettura, con la sua struttura scheletrica minimale la libreria evoca l'eleganza di travi e pilastri, mentre una volta abitata, diviene un'opera in continua evoluzione, plasmata dagli oggetti in essa contenuti.

Il suo tocco distintivo risiede nel posizionamento personalizzabile di vassoi circolari colorati, che richiamano l'idea della bolla: un elemento dinamico, mai uguale e in continuo mutamento.

EN Bubble is a modular bookcase designed by Gianmarco Miolo, combining formal rigor with the dynamism of shapes. Inspired by architecture, the bookcase evokes elegance through its minimal structure, remindful of beams and pillars. Once inhabited, it transforms into a constantly evolving work shaped by the objects it contains.

Its distinctive touch lies in the customizable placement of colorful circular trays, reminiscent of the concept of a bubble: a dynamic element, never the same and constantly changing.





**Bubble Alta** H 2100 mm, struttura in Carbon Oak, ripiani metallici in Copper e Beige red, ripiani in vetro sp. 8 mm. Ambiente: residenziale, living

**Bubble High** H 2100 mm, frame in Carbon Oak, metal trays in Copper and Beige red, glass shelves 8 mm thickness. Environment: residential, living



**Bubble Alta** H 2100 mm, struttura in Carbon Oak, ripiani metallici in Distant blue e Pastel blue, ripiani in legno in Carbon Oak sp. 19 mm. Ambiente: ufficio

**Bubble High** H 2100 mm, frame in Carbon Oak, metal trays in Distant blue and Pastel blue, wooden shelves in Carbon Oak 19 mm thickness. Environment: office

**Bubble Bassa** H 850 mm, struttura in Carbon Oak, ripiani metallici in Distant blue e Pastel blue, ripiani in legno in Carbon Oak sp. 19 mm. Ambiente: ufficio

**Bubble Low** H 850 mm, frame in Carbon Oak, metal trays in Distant blue and Pastel blue, wooden shelves in Carbon Oak 19 mm thickness. Environment: office

## Un'esperienza di design in costante effervescenza A design experience in constant effervescence

IT Bubble sfida il concetto convenzionale di arredamento statico, dando la libertà di combinare elementi e contenuti della libreria a piacimento. I vassoi colorati, integrati nella struttura della libreria, si distinguono per le loro dimensioni e versatilità: possono essere spostati liberamente, facendoli scorrere sulla struttura in legno impiallacciato.

La straordinaria adattabilità alle necessità mutevoli di chi li utilizza, li trasforma da semplici componenti d'arredo a veri elementi dinamici, che contribuiscono a ridefinire l'ambiente con un tocco di design e innovazione.

EN Bubble challenges the conventional concept of static furniture, providing the freedom to combine elements and contents of the bookcase as desired. The colored trays, integrated into the structure of the bookcase, stand out for their size and versatility: they can be moved freely by sliding them along the veneered wood structure.

The extraordinary adaptability to the changing needs of the user transforms them from simple furniture components into true dynamic elements, contributing to redefining the environment with a touch of design and innovation.

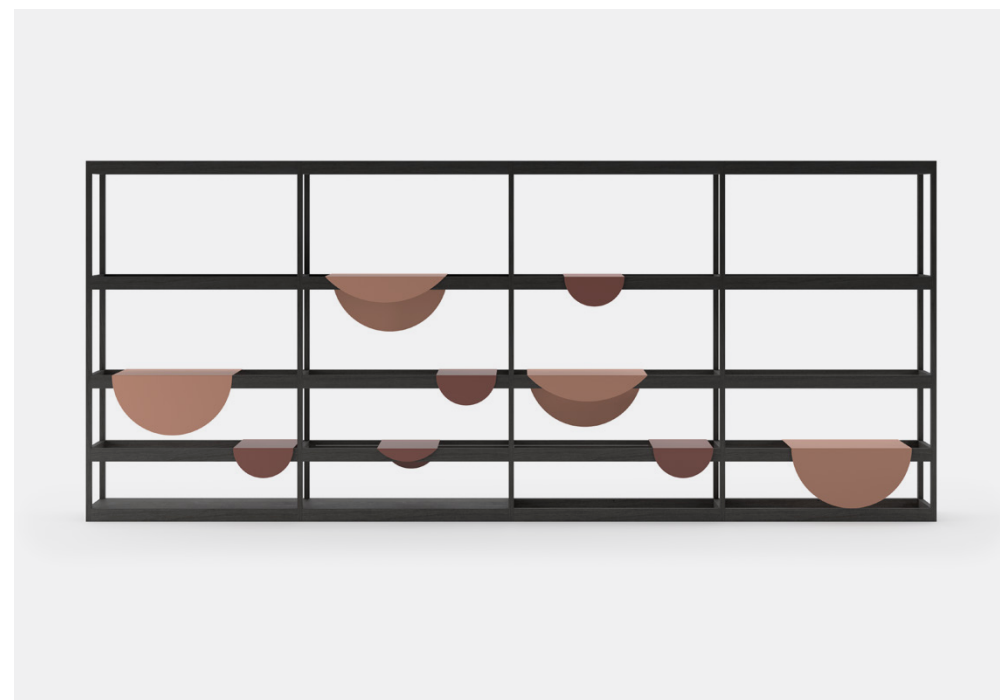
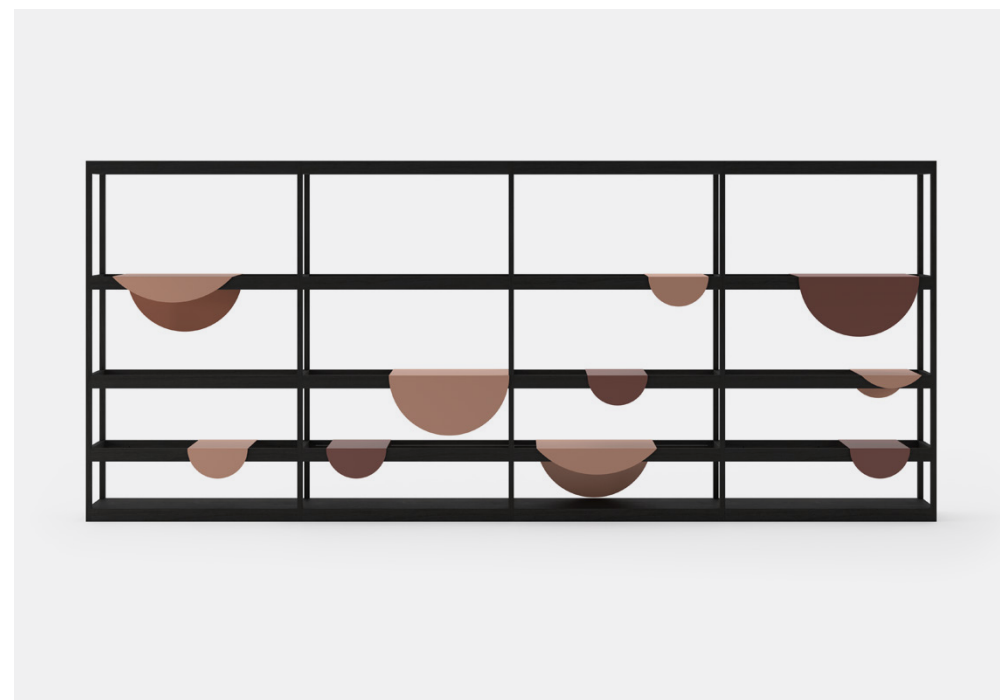



## Sospesi in trasparenza Suspended in transparency

IT La libreria Bubble si trasforma ulteriormente in un'opera architettonica dinamica grazie alla possibilità di personalizzarla con mensole in vetro. L'effetto è scenico: gli oggetti personali, una volta posizionati sopra, sembrano fluttuare nell'aria. In alternativa, la rimozione delle mensole offre spazio e flessibilità nella gestione di oggetti di diverse dimensioni. Questa versatilità conferisce alla libreria un aspetto architettonico a doppia o tripla altezza, mantenendo un tocco di creatività senza rinunciare all'eleganza.

EN The Bubble bookcase further transforms into a dynamic architectural piece, thanks to the option of customizing it with glass shelves. The result is fascinating: personal items placed on these surfaces seem to float in mid-air. Alternatively, removing the shelves opens up space and flexibility for managing objects of different sizes. This versatility gives the bookcase a double or triple height architectural appearance, adding a touch of creativity while retaining its elegant appeal.



**Bubble Alta** H 2100 mm, struttura in Carbon Oak, ripiani metallici in Distant blue e Pastel blue, ripiani in legno in Carbon Oak sp. 19 mm. Ambiente: ufficio

**Bubble High** H 2100 mm, frame in Carbon Oak, metal trays in Distant blue and Pastel blue, wooden shelves in Carbon Oak 19 mm thickness. Environment: office



Un design sostenibile che si adatta al tuo spazio  
A sustainable design that adapts to your space

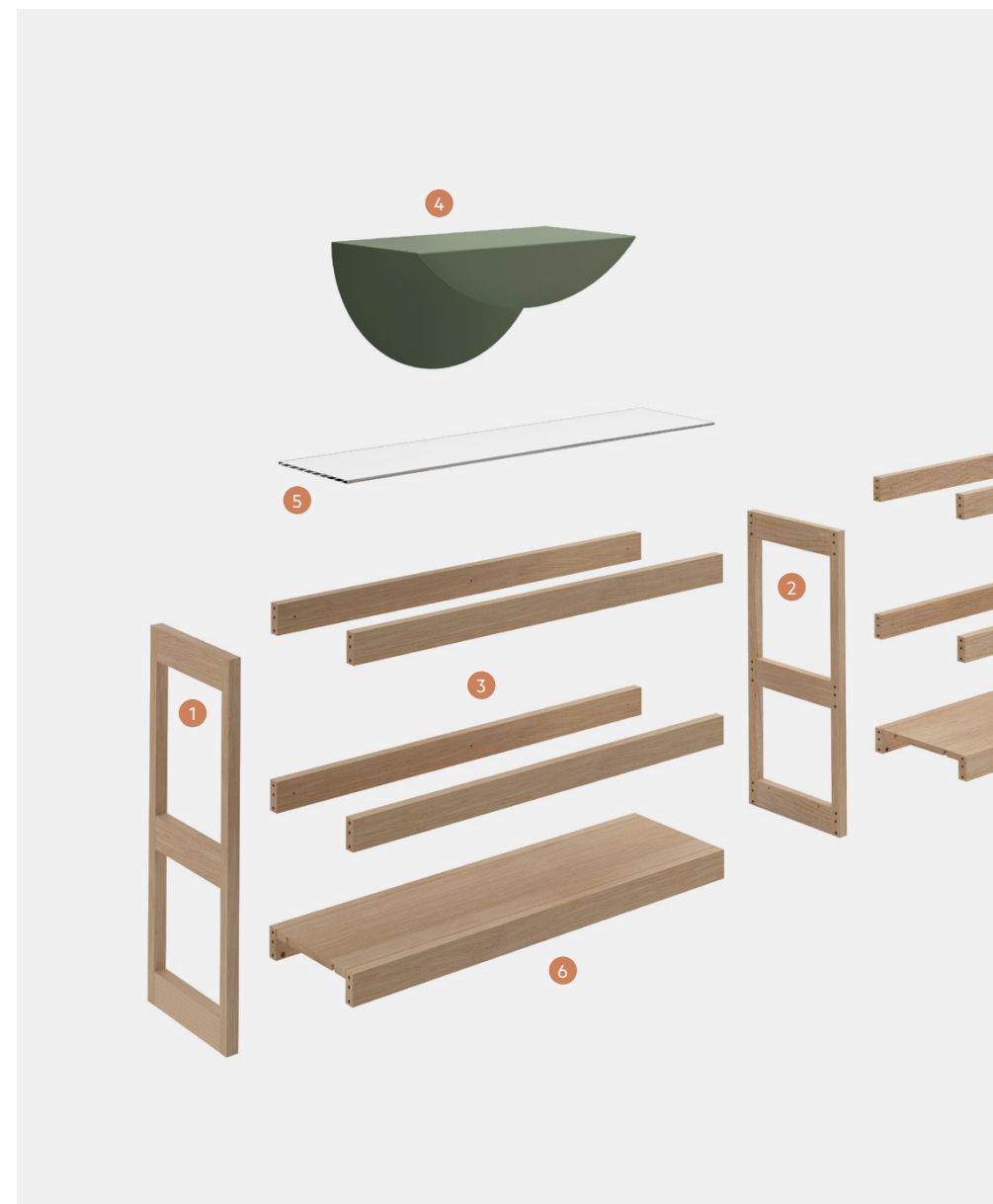

IT Ogni elemento di Bubble è pensato per essere spedito in modo compatto, riducendo l'impatto ambientale. Scegli un'esperienza di design personalizzabile e sostenibile.

EN Each component of Bubble is designed to be shipped compactly, minimizing environmental impact. Choose a customizable and sustainable design experience.

01 Fianco laterale / Side panel  
02 Fianco intermedio / Intermediate side panel

03 Traversi / Crosspieces  
04 Vassoio Bubble in metallo / Bubble metal tray

05 Ripiano in vetro o legno / Glass or wooden shelf  
06 Basamento ispezionabile / Inspectable base

# Caratteristiche tecniche Technical features

## Bubble Bassa / Bubble Low

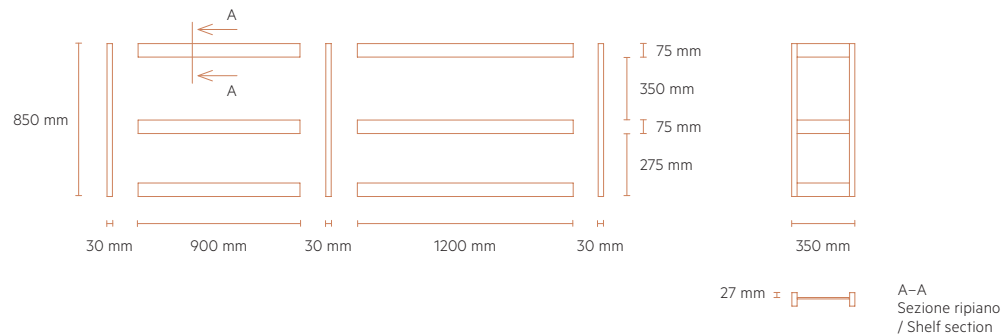

## Bubble Alta / Bubble High

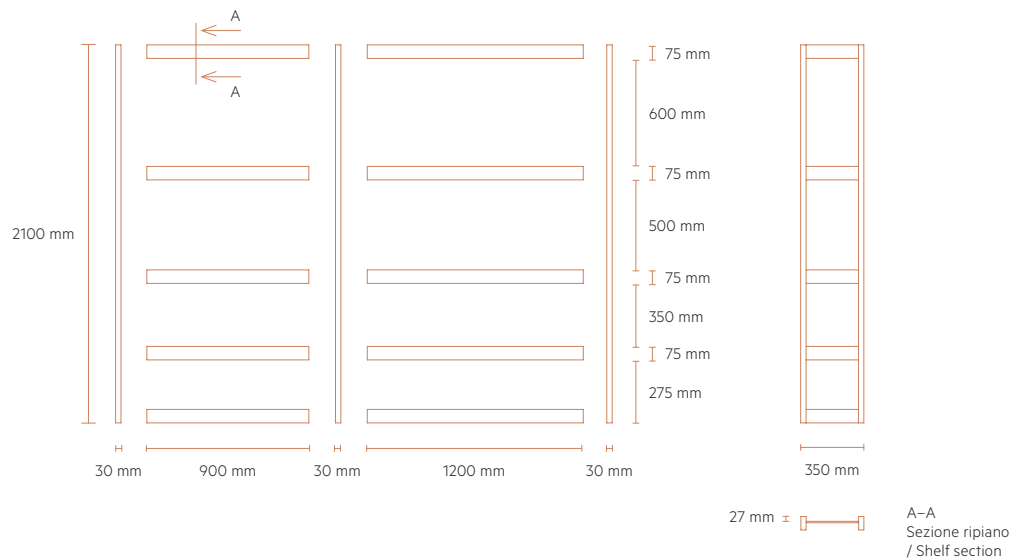

## Vassoio grande / Big tray

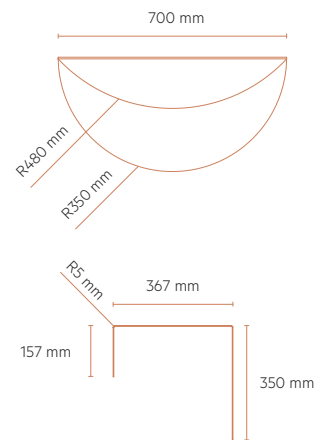

## Vassoio piccolo / Small tray

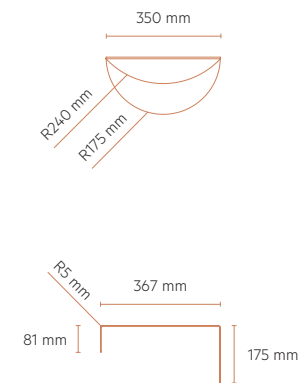

## Ripiani / Shelves

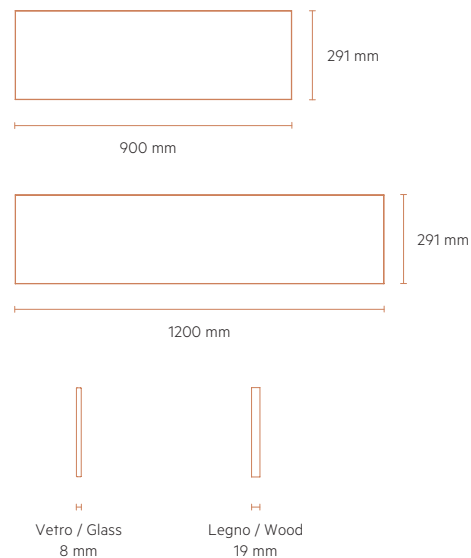

## Reggilibro / Bookend

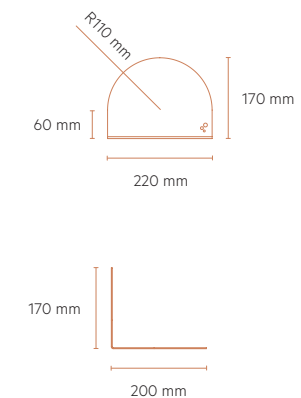

# Esempi di configurazioni

## Configuration examples

**Bubble Bassa 1 / Bubble Low 1**

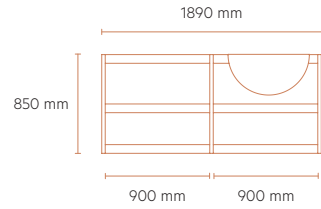

**Bubble Bassa 2 / Bubble Low 2**

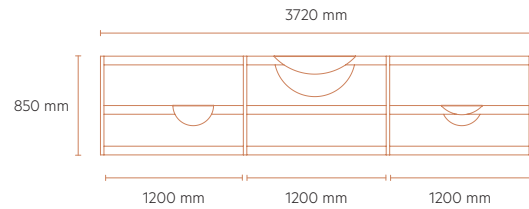

**Bubble Bassa 3 / Bubble Low 3**

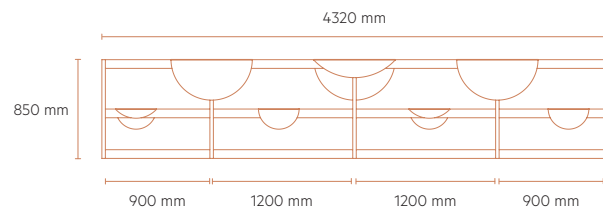

**Bubble Alta 1 / Bubble High 1**

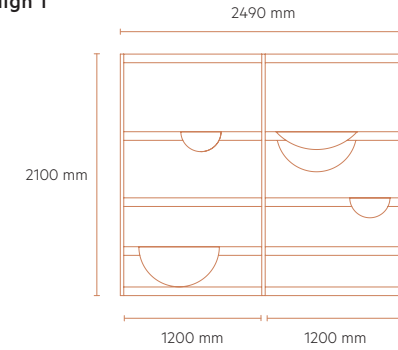

**Bubble Alta 2 / Bubble High 2**

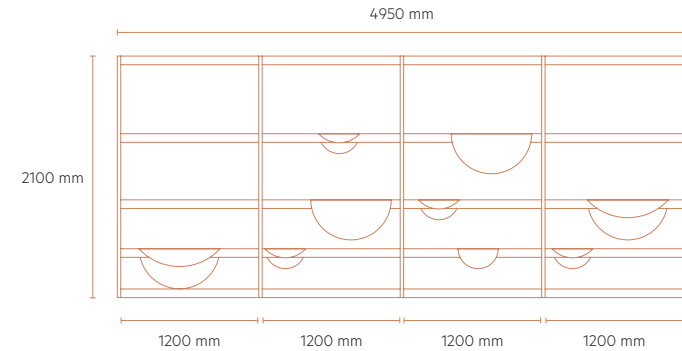

**Bubble Alta 3 / Bubble High 3**

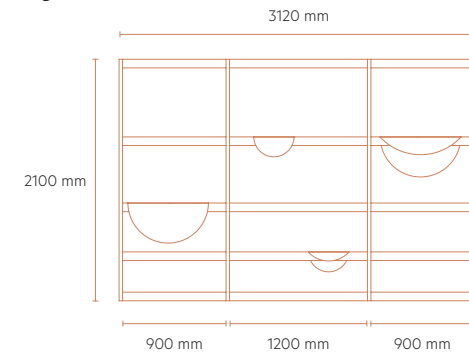

## Finiture Finishes

### Legni Woods



Fresh oak



Carbon oak



Canaletto



Velasca

### Metalli verniciati trasparenti Transparent lacquered metals



Natural

### Metalli verniciati colorati Coloured lacquered metals



Jet black

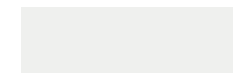

Traffic white



Olive drab



Champagne



Traffic grey B



Telegrey 4



Pure orange



Beige red



Copper



Ultramarine blue



Distant blue



Pastel blue



Signal green



Raseda green



Pale green

IT L'essenza di Bubble si esprime nella modularità dinamica: questo consente la creazione di un pezzo unico attraverso scelte articolate di finiture, dimensioni e colori, che possono cambiare nel tempo.

Dalla struttura portante in legno alle vibranti tonalità dei vassoi in metallo, ogni elemento di Bubble può essere personalizzato a piacimento.

EN The essence of Bubble is expressed in its dynamic modularity: this allows the creation of a unique piece through articulate choices of finishes, dimensions and colors, which can evolve over time.

From the wooden frame to the vibrant hues of the metal trays, every element of Bubble can be tailored to personal preferences.

## Xilia, wood spaces with an emotional touch

IT Xilia è specializzata nella progettazione e produzione di sistemi di dressing dello spazio composti da rivestimenti a parete e soffitto, porte e armadiature integrate. A questi si uniscono complementi dalla spiccata personalità, in cui il denominatore comune è rappresentato dall'esperienza tattile della superficie.

Le soluzioni Xilia migliorano la percezione degli spazi, trasformando le idee creative in prodotti intelligenti, funzionali e sostenibili dal grande appeal estetico. Un mondo di sensazioni nel palmo della mano.

EN Xilia is specialized in the design and production of dressing systems made of wall and ceiling coverings, doors and integrated wardrobes. These are complemented by distinctive accessories, in which the common denominator is represented by the tactile experience of the wooden surface.

Xilia solutions improve the perception of spaces, transforming creative ideas into intelligent, functional and sustainable products with great aesthetic appeal. A world of sensations in the palm of your hand.

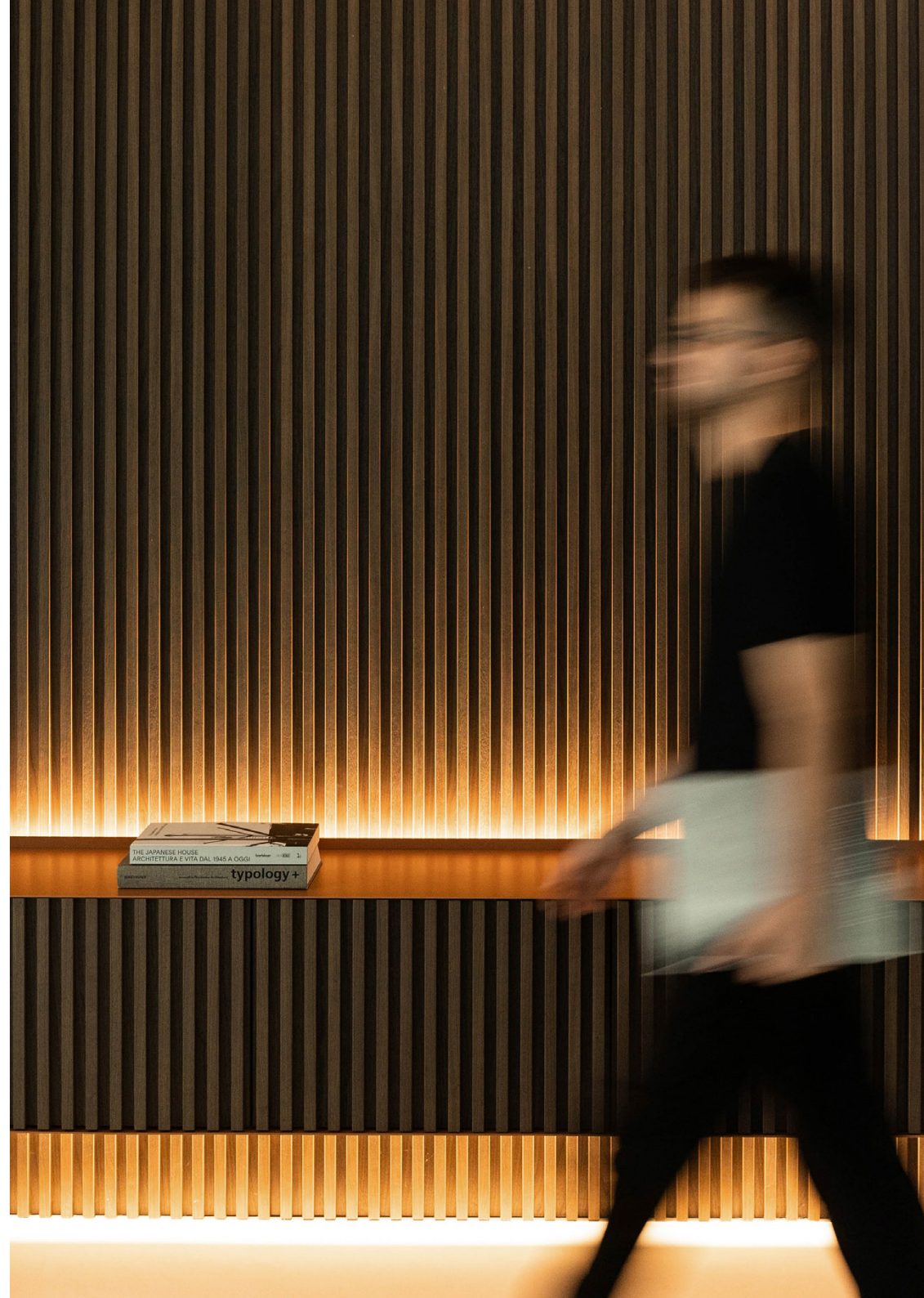

## CREDITS

Concept: Gianmarco Miolo

Engineering: Xilia R&D

Render: Orygine

Art Direction & Graphics: Studio Nuvole

Thanks to:

Alessi, Apple, Beats, Flos, Knoll, Olivetti, Vitra

Copyright © 2024 Xilia Wood Experience.

Tutti i diritti riservati. Nessuna parte di questo catalogo può essere riprodotta in qualsiasi forma mediante stampa, fotocopia, microfilm, registrazione o altri mezzi senza previa autorizzazione scritta degli editori. L'azienda ha il diritto di modificare i propri prodotti al fine di migliorarne la qualità in qualsiasi momento senza preavviso.

Copyright © 2024 Xilia Wood Experience.

All rights reserved. No part of this catalogue may be reproduced in any form by print, photocopy, microfilm, recording or other means without the prior written permission of the publishers. The company is entitled to modify its products to the aim of improving their quality at any time without giving prior notice.

## HEADQUARTER & SHOWROOM

Via Callalta Capoluogo, 12

31045 Motta di Livenza (TV) - Italy

info@xiliawood.com

+39 0422 1626003

XILIAWOOD.COM

